

APLISENS[®]

USER MANUAL

ELECTROMAGNETIC FLOWMETER **PEM-500**

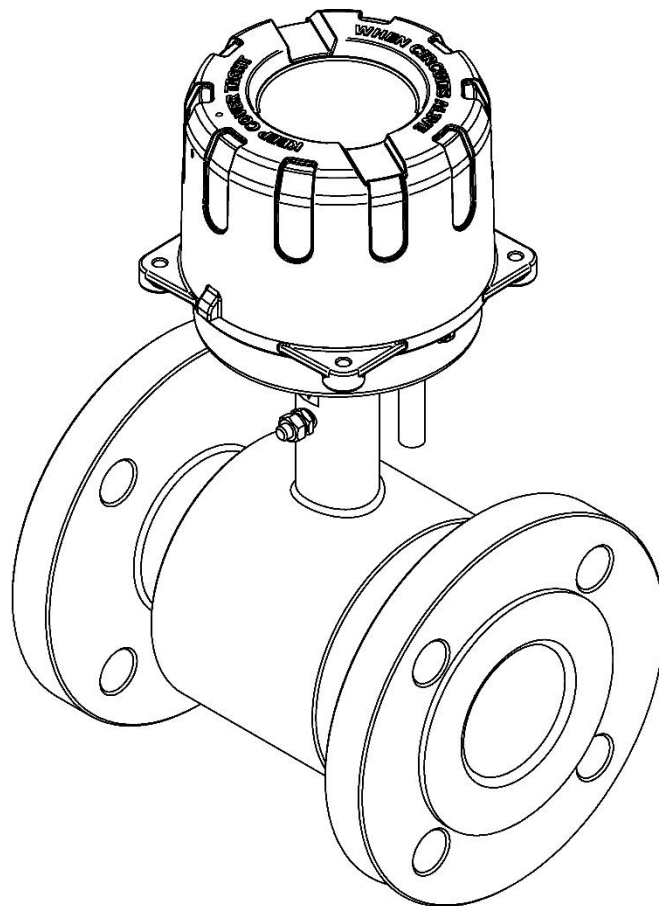

PRODUCT CODE – see: ([→ Flowmeter identification](#)).



The QR code or link identifies the flowmeter and provides quick access to the following documentation on the manufacturer's website: user's manual, MODBUS manual, configuration manual, declarations of conformity and copies of certificates.

PEM-500

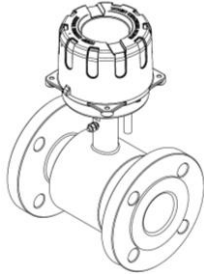
<https://www.aplisens.pl/ID/00260011000900000000000000352/>



Symbols used

Symbol	Description
	Warning to proceed strictly in accordance with the information contained in the documentation in order to ensure the safety and full functionality of the device.
	Information particularly useful during installation and operation of the device.
	Information on disposal of used equipment.

BASIC REQUIREMENTS AND SAFE USE



The manufacturer will not be liable for damage resulting from incorrect installation, failure to maintain a suitable technical condition of the device or use of the device other than for its intended purpose.

Installation should be carried out by qualified staff having the required authorizations to install electrical and I&C equipment. The installer is responsible for performing the installation in accordance with manual as well as with the electromagnetic compatibility and safety regulations and standards applicable to the type of installation.

In systems with I&C equipment, in case of leakage, there is a danger to staff due to the medium under pressure. All safety and protection requirements must be observed during installation, operation and inspections.

If a malfunction occurs, the device should be disconnected and handed over to the manufacturer for repair.



In order to minimize the risk of malfunction and associated risks to staff, the device is not to be installed or used in particularly unfavourable conditions, where the following hazards occur:

- possible mechanical impacts, excessive shocks and vibration;
- excessive temperature fluctuation;
- water vapour condensation, dusting, icing.

Changes made to the manufacturing of products may be introduced before the paper version of the manual is updated. The up-to-date manuals are available on the manufacturer's website: www.aplisens.com.

TABLE OF CONTENTS

1. INTRODUCTION	6
1.1. Trademarks.....	6
2. SAFETY	6
3. TRANSPORT AND STORAGE	6
3.1. Delivery check.....	6
3.2. Transport.....	6
3.3. Storage.....	6
5. IDENTIFICATION	7
5.1. Manufacturer's address.....	7
5.2. Flowmeter identification.....	7
5.3. CE mark, declaration of conformity.....	8
6. CONSTRUCTION	8
6.1. Intended use and features.....	8
6.2. Design and overall dimensions.....	8
6.2.1. Electrodes.....	10
7. INSTALLATION	11
7.1. General recommendations.....	11
7.2. Recommended assembly method for the sensor.....	11
7.3. Installation of the PEM-500 flowmeter.....	13
8. ELECTRICAL CONNECTION	14
8.1. Grounding.....	16
9. START-UP	17
10. TECHNICAL PARAMETERS	17
10.1. Electrical connections.....	17
10.1.1. Output signals.....	17
10.1.2. Power supply.....	17
10.2. Protection class.....	17
10.3. Technical parameters.....	18
10.3.1. Technical specifications.....	18
10.4. Reference conditions.....	18
10.5. Metrological parameters.....	19
10.5.1. Standard measuring ranges.....	19
10.5.2. Table of volumetric flows calculated for characteristic fluid flow velocities for flanged execution acc. to DIN.....	20
10.5.3. Available pressure ranges acc. to DIN, ANSI of flowmeters operation for individual designs of DN size of flange connections.....	21
10.5.4. Selection of the diameter and measuring range of the flowmeter.....	21
10.6. Permissible ambient and operating parameters.....	22
11. MAINTENANCE	23
11.1. Periodic inspections.....	23
11.2. Non-periodic inspections.....	23
11.3. Cleaning / washing.....	23
12. SCRAPPING, DISPOSAL	23
13. ADDITIONAL INFORMATION	23
13.1. History of revisions.....	23

LIST OF DRAWINGS

Figure 1. Nameplate of the PEM-500.....	7
Figure 2. Overall dimensions of the flowmeter transmitter.....	8
Figure 3. Overall dimensions of the sensor.....	9
Figure 4. Recommended installation of the sensor.	11
Figure 5. Installation of the PEM-500 flowmeter – examples.....	13
Figure 6. Example of functional earthing connection for metallic (A) piping and for insulated piping using earthing rings (B)	16
Figure 7. Connection of the functional earthing to the sensor enclosure.	16
Figure 8. Recommended flow values for the PEM-500 flowmeter.	21
Figure 9. “Outputs” tab view – setting the flow values for 4 mA and 20 mA current.....	22

LIST OF TABLES

Table 1. PN 16 sensor data.....	9
Table 2. PN 25 sensor data.....	10
Table 3. PN 40 sensor data.....	10
Table 4. Marking of power and signal conductors for the low voltage version (24 V).	14
Table 5. Marking of power conductors for the high-voltage version (230 V).	14
Table 6. Marking of signal conductors for the high-voltage version (230 V).....	15
Table 7. Technical data od PEM-500 flowmeter.	18
Table 8. Flow values for the PEM-500 flowmeter.	19
Table 9. Volume flow versus fluid linear velocity.	20
Table 10. Flow values corresponding to the velocity of 1 m/s.....	20

1. INTRODUCTION

The user manual covers the electromagnetic flowmeter **PEM-500**.

The manual contains data, tips and general recommendations for the safe installation and operation of the flowmeter.



The description of the flowmeter configuration is given in the configuration manual EN.IK.PEM.500, whereas the Modbus[®] communication is described in the MODBUS manual EN.IM.PEM.500.

These manuals are available on the manufacturer's website www.aplisens.com.

1.1. Trademarks

Modbus[®] is a registered trademark of SCHNEIDER AUTOMATION, INC.

2. SAFETY



- The installation and start-up of the device and any activities related to operation shall be carried out after thorough examination of the contents of user manual and the instructions related thereto.
- Installation and maintenance should be carried out by qualified staff having the required authorizations to install electrical and measuring devices.
- The device shall be used according to its intended purpose in line with the permissible parameters specified on the nameplate → Flowmeter identification.
- The protecting elements used by the manufacturer to ensure flowmeter safety may be less effective if the device is operated in a manner not consistent with its intended purpose.
- Before installing or disassembling the device, it is absolutely necessary to disconnect it from the power source.
- No repairs or alterations of the flowmeter electronic system are permitted. Assessment of damage and possible repair may only be performed by the manufacturer or authorized representative.
- Do not use instruments if damaged. In case of malfunction, the device must be put out of operation.

3. TRANSPORT AND STORAGE

3.1. Delivery check

After receiving the delivery of the equipment, it is necessary to:

- make sure that the packaging and its contents were not damaged during transport;
- check the completeness and correctness of the received order, and make sure no parts are missing.

3.2. Transport

Transport of flowmeters shall be carried out with the use of covered means of transport, in original packages. The packaging shall be protected against movement and direct impact of atmospheric factors.

3.3. Storage

Flowmeter shall be stored in an original packaging, in a room, without vapours and aggressive substances, protected against mechanical impact. The temperature and relative humidity shall not exceed the parameters specified in section → 10.6.

4. GUARANTEE

General terms and conditions of guarantee are available on the manufacturer's website:
www.aplisens.com/ogolne_warunki_gwarancji

i The guarantee shall be repealed if the device is used in against its intended use, failure to comply with user's manual or interference with the structure of the device.

5. IDENTIFICATION

5.1. Manufacturer's address

APLISENS S.A.
 03-192 Warsaw
 Morelowa 7 St
 Poland

5.2. Flowmeter identification

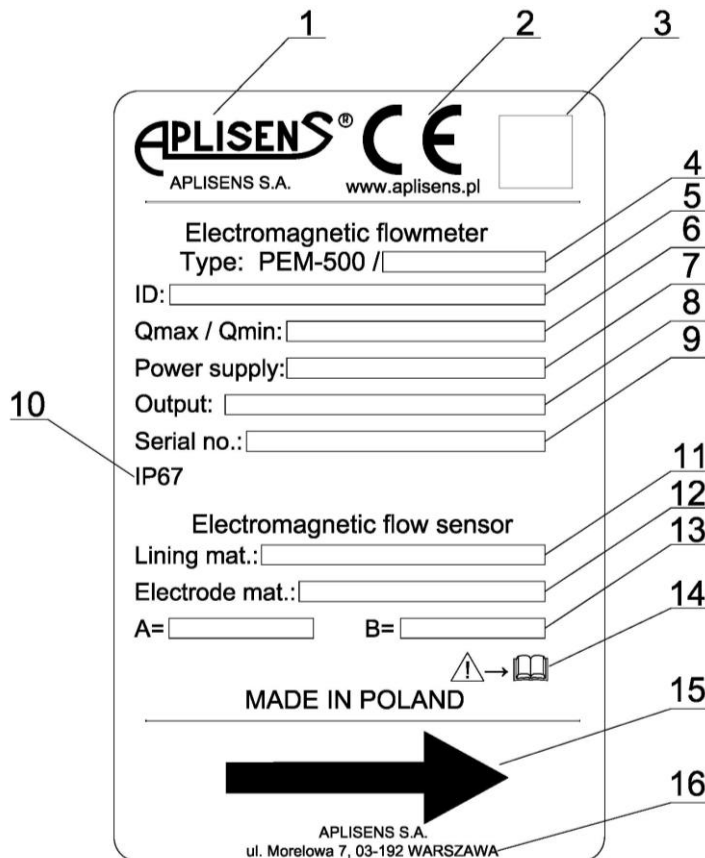

Figure 1. Nameplate of the PEM-500.

- | | |
|-----------------------------------|---|
| 1. Logo and name of manufacturer. | 10. IP rating. |
| 2. CE mark. | 11. Insulation lining material. |
| 3. QR product code. | 12. Material of electrodes. |
| 4. Flowmeter type. | 13. A and B factor values. |
| 5. Flowmeter model ID. | 14. Note about the obligation to read the manual. |
| 6. Max/Min flow value. | 15. Direction of fluid flow. |
| 7. Supply voltage values. | 16. Manufacturer's address. |
| 8. Output signal. | |
| 9. Flowmeter serial number. | |

5.3. CE mark, declaration of conformity

The device has been designed to meet the highest safety standards, has been tested and has left the factory in a condition that is safe for operation. The device complies with the applicable standards and regulations listed in the EU Declaration of Conformity and has CE marking on nameplate.

6. CONSTRUCTION

6.1. Intended use and features

The electromagnetic flowmeter PEM-500 is designed for volumetric measurement of the flow rate of conductive liquids in piping systems. It measures the flow and volume of the fluid flowing in both directions. Complete filling of the sensor tube by the fluid is required for correct measurement.

The flowmeter can be used to measure the flow of clear liquids, suspensions, pulp, solutions of various chemical aggressiveness. Lack of mechanical components ensures high durability of the instrument even when measuring abrasive fluids.

The compact enclosure with IP67 rating (IP68 special design) allows to install the equipment buried underground.



The transmitter converts the measuring signal coming from the measuring sensor to 4...20 [mA] signal and Modbus RTU/RS485.

The configuration and reading of the flowmeter parameters are done via the RS485 interface and Modbus RTU protocol using a PC equipped with RS485/USB converter and Raport 2 or other software, interfacing with the flowmeter registers according to the interface documentation. Any HMI panel running as Modbus master can also be used to visualize data.

6.2. Design and overall dimensions

The electromagnetic flowmeter PEM-500 consists of a transmitter and a measuring sensor forming a fixed assembly.

The transmitter enclosure is made of high pressure aluminum casting. The user has no access to the part containing the electronics board.

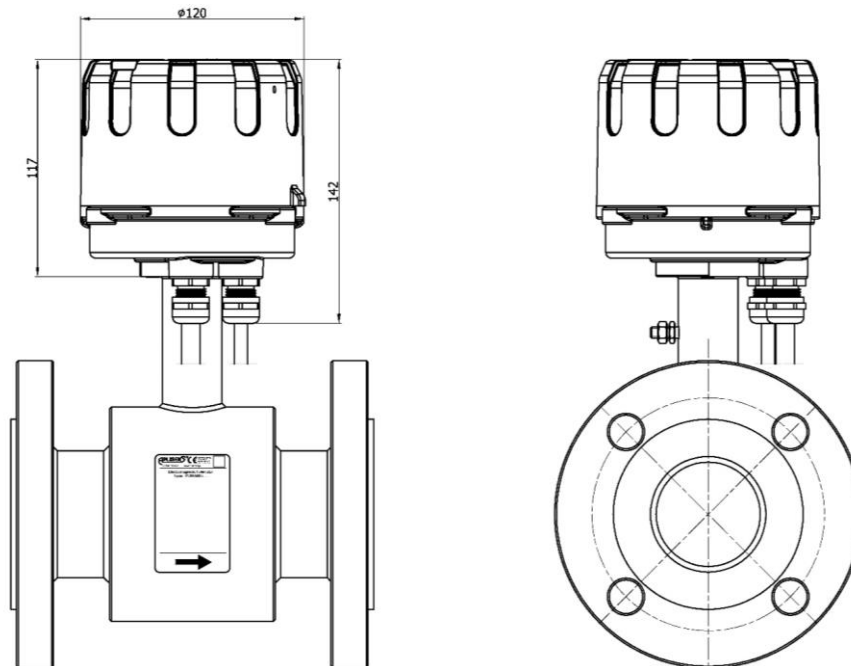
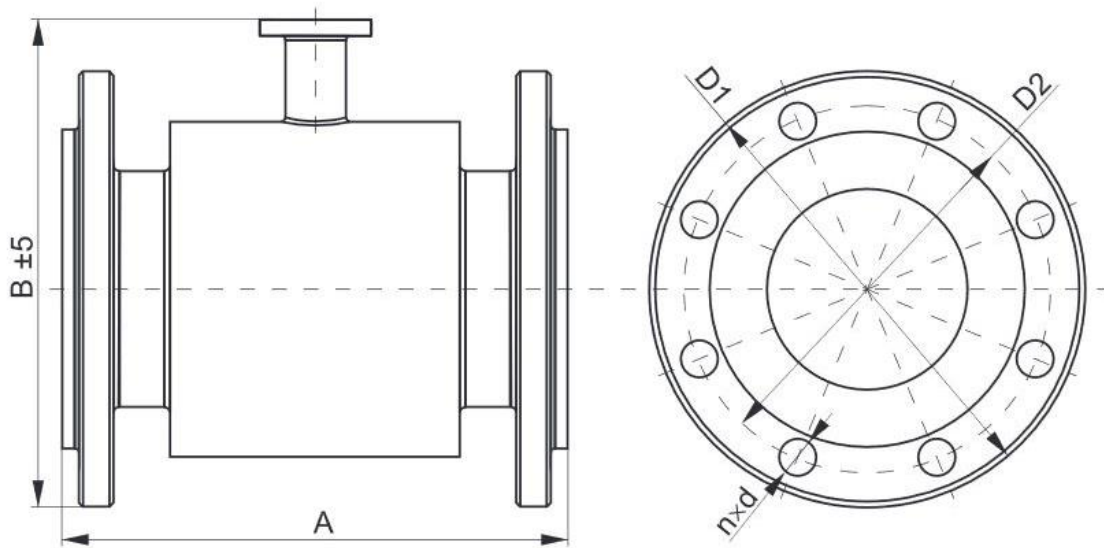

Figure 2. Overall dimensions of the flowmeter transmitter.

The sensor enclosure is made of non-magnetic material, welded with flanges and a set of fastenings. An insulating insert of the required properties is placed inside the tube (compatible with the type of fluid). The system of electromagnet coils generating the required magnetic field is fixed directly on the measuring tube.

A pair of electrodes positioned opposite to one another and passing through the measuring tube with lining is made of acid resistant steel or other electrically conductive materials selected to fit the chemical properties of the measured fluid. The flowmeter sensor has no internal mechanical components, which ensures undisturbed flow of the measured fluid through the complete cross-section of the piping. The flow measurement is independent of:

- fluid pressure;
- viscosity;
- density;
- temperature;
- electrical conductivity (above the minimum value).



DN 10 – DN 150 A ± 5 mm, DN 200, DN 250 A ± 10 mm

Figure 3. Overall dimensions of the sensor.

Table 1. PN 16 sensor data.

DN	Dimensions [mm]						Weight [kg]
	A	B	D1	D2	d	n	
10	150 or 200	153	90	60	14	4	2,5
15		155	95	65	14	4	2,5
20		160	105	75	14	4	3
25		167	115	85	14	4	3,5
32		180	140	100	18	4	5
40		185	150	110	18	4	6
50	200	191	165	125	18	4	7
65		209	185	145	18	4	8
80		224	200	160	18	8	9,5
100	250	245	220	180	18	8	12
125		276	250	210	18	8	15
150		305	285	240	22	8	20
200	350	375	340	295	22	12	36
250	400	430	405	355	26	12	58

Table 2. PN 25 sensor data.

DN	Dimensions [mm]						Weight [kg]
	A	B	D1	D2	d	n	
10	150 or 200	153	90	60	14	4	2,5
15		155	95	65	14	4	2,5
20		160	105	75	14	4	3
25		167	115	85	14	4	3,5
32		180	140	100	18	4	5
40		185	150	110	18	4	6
50	200	191	165	125	18	4	7
65		209	185	145	18	4	8
80		224	200	160	18	8	9,5
100	250	245	235	190	22	8	12
125		276	270	220	26	8	15
150	300	305	300	250	26	8	20
200	350	375	360	310	26	12	36
250	400	430	425	370	30	12	58

Table 3. PN 40 sensor data.

DN	Dimensions [mm]						Weight [kg]
	A	B	D1	D2	d	n	
10	150 or 200	153	90	60	14	4	2,5
15		155	95	65	14	4	2,5
20		160	105	75	14	4	3
25		167	115	85	14	4	3,5
32		180	140	100	18	4	5
40		185	150	110	18	4	6
50	200	191	165	125	18	4	7
65		209	185	145	18	4	8
80		224	200	160	18	8	9,5
100	250	245	235	190	22	8	12
125		276	270	220	26	8	15
150	300	305	300	250	26	8	20
200	350	375	375	320	30	12	36
250	400	430	450	385	33	12	58

6.2.1. Electrodes

The material of the electrodes of the flow sensor has to be selected to correspond with its chemical resistance to the fluid in which the electrodes will be immersed.

Cleanliness of electrodes can affect the precision of the measurement and the accumulation of dirt can affect the measuring process (liquid isolation). Cleaning details are specified in section → [11.3](#).

7. INSTALLATION

7.1. General recommendations



- It is recommended that the flow direction matches the direction of the arrow on the sensor; the transmitter is set by default to operate in that direction. It is possible to reverse the flow direction on the instrument in operation, but then the flow direction must also be changed in transmitter parameters.
- Before installation, check if there is enough space to install the flowmeter at the flange using the bolts and nuts available.
- During the measurement, the entire space inside the sensor should be filled with the measured liquid.
- Secure the piping system in place on both sides of the flowmeter to prevent the vibrations and deflections of the system from affecting the measurement.
- If the flowmeter is installed on a pipeline with a larger internal diameter, a reducer must be used to ensure alignment upon installation without any stress increase in sensor piping and flanges.
- During installation, ensure there are straight sections with a nominal diameter matching the nominal diameter of the sensor (DN) with the minimum length of: 5DN upstream and 3DN downstream the sensor.
- When installing the sensor on an insulated pipe (e.g. glass, plastic, etc.), ground the complete system with earthing rings connected to the sensor ground terminal → [Figure 6](#).
- A conductive connection between the sensor ground (enclosure) and the liquid is necessary for proper measurement.
- During installation, it is necessary to install a seal between the sensor piping flanges. If earthing rings are used, the seal must be inserted on both sides of the ring.
- Do not use gaskets made of hard materials as they may damage the Teflon lining or, in the case of rubber lining, not ensure sufficient tightness of the installation.
- Make sure that no sealing element enters the lumen of the pipeline as this may introduce turbulence into the flow and disrupt the operation of the flowmeter.

7.2. Recommended assembly method for the sensor

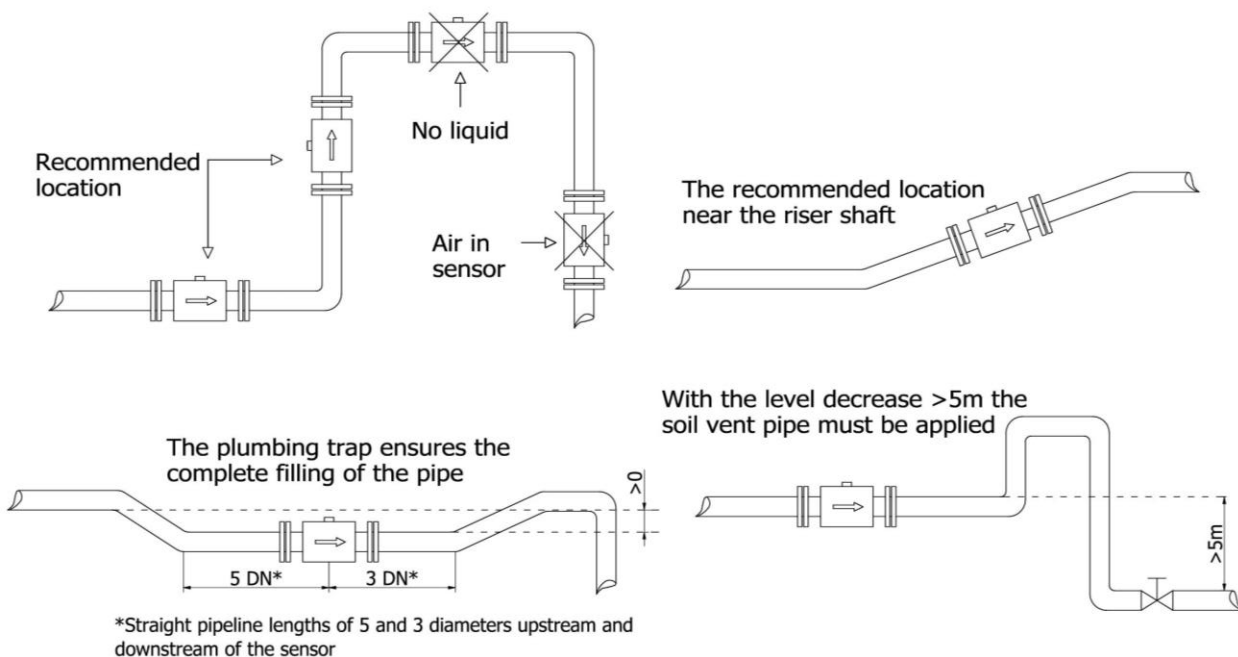

Figure 4. Recommended installation of the sensor.

In order to avoid metrological errors caused by air bubbles or lining damage, the following points must be observed:

- during installation, the sensor must be properly positioned, the flange bolts must be tightened simultaneously on both sides;
- it is recommended that the flowmeter be installed so that the axis of the electrodes is as horizontally as possible as shown by the examples in → [Figure 5](#);
- Teflon lining needs special attention during operation and installation. During installation (operation) excessive vacuum in the piping should be avoided. Do not damage the lining edges extending to the outer flange surfaces on both sides of the sensor. Some sensors are factory supplied with special covers to prevent deformation of the Teflon lining. Covers should be removed immediately before installation, before inserting between the counter-flanges;
- ensure that no sealing element protrudes into the piping passage as this can cause turbulence of the flow and disturb the flowmeter operation.

7.3. Installation of the PEM-500 flowmeter

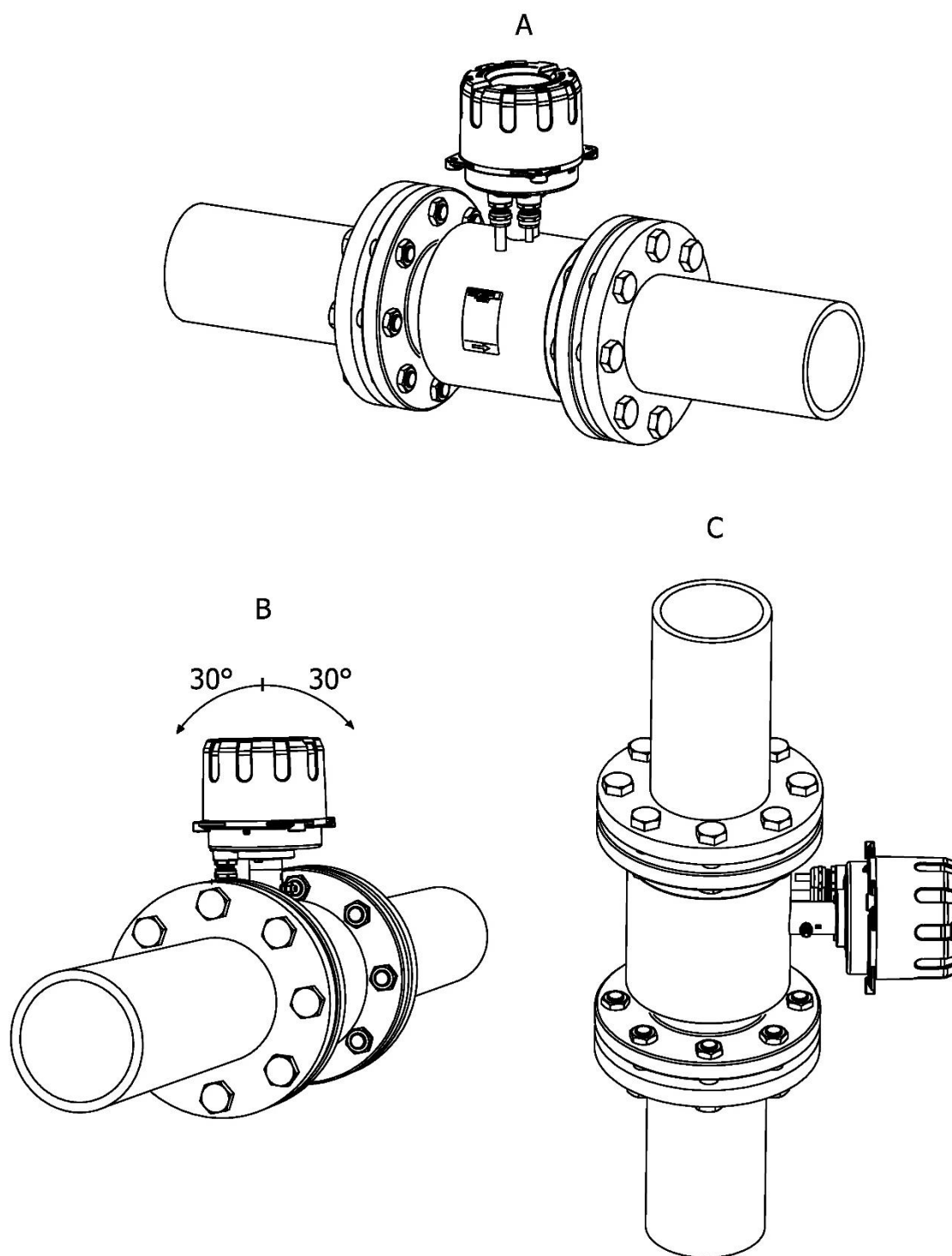

Figure 5. Installation of the PEM-500 flowmeter – examples.



It is recommended to install the flowmeter in the horizontal (A) position (it is possible to deviate from the horizontal plane by approx. 30° (B)) and in the vertical (C) position – according to the examples presented in Fig. 5. Otherwise, it is possible to generate an empty pipe detection alarm when there is air in the system (one of the electrodes is not immersed).

8. ELECTRICAL CONNECTION



All connection and installation operations must be performed with supply voltage and other external voltages (if used) disconnected. A circuit breaker must be installed next to the flowmeter transmitter (in the same room) on the flowmeter feeding line. It must be easily accessible and clearly and unambiguously marked with symbols compliant with local electrical equipment safety regulations.

The user has no access to the part containing the electronics board.

The electrical connection of the flowmeter is made with the pre-installed cables with leads marked, depending on the type of cable used, by colours or numbers. The designation and numbering of conductors is shown in Table 4.

The number of cables depends on the selected power supply option of the flowmeter. The version with mains power supply has two cables — signal and power supply, and the low voltage version has one cable for power supply and signaling. As a standard, the flowmeter is equipped with 3-metre long cable.

Table 4. Marking of power and signal conductors for the low voltage version (24 V).

	Wire colour	Wire number **	Description	
Power supply	Blue	3	Power supply	(-)
	Brown	4		(+)
2-state output	Transparent	10	Any polarity, galvanic isolated passive	
	Gray	5		
Output pulse / frequency	Pink	8	Any polarity, galvanic isolated passive	
	Violet	7		
Analog output, active 4÷20 mA	Red	6	(+)	Active/passive (normally active)
	Black	2	(-)	
Communication	Black-white	12	RS485 A	
	Blue-white	13	RS485 B	
	White	1	RS485 GND	
2-state input passive	Orange	9	Any polarity, galvanic isolated	
	Beige	11		
Functional grounding	Yellow-green	0	Connected internally to the housing	

** If a cable with numbered conductors is used, the table numbering according to VDE 0293 shall apply.

The high-voltage version is equipped with two cables:

- power supply (3-wire);
- signal (14-wire).

Table 5. Marking of power conductors for the high-voltage version (230 V).

	Wire colour	Description	
3 wire cable	Blue	N	Mains supply
	Brown	L	
	Yellow-green	Protective grounding	Connected internally of the housing

Table 6. Marking of signal conductors for the high-voltage version (230 V).

	Wire colour	Wire number**	Description	
-	Blue	3	Not used in high voltage version	
	Brown	4		
2-state output	Transparent	10	Any polarity, galvanic isolated passive	
	Gray	5		
Output pulse / frequency	Pink	8	Any polarity, galvanic isolated passive	
	Violet	7		
Analog output, active 4÷20 mA	Red	6	(+)	Active/passive (normally active)
	Black	2	(-)	
Communication	Black-white	12	RS485 A	
	Blue-white	13	RS485 B	
	White	1	RS485 GND	
2-state input passive	Orange	9	Any polarity, galvanic isolated	
	Beige	11		
-	Yellow-green	0	Not used in high voltage version	

** If a cable with numbered conductors is used, the table numbering according to VDE 0293 shall apply.

When connecting the flowmeter to the electrical power supply, you must observe the following rules regarding:

- connections of electrical equipment;
- protections against electric shock;
- principles of safe operation of electrical systems by personnel.

The electrical protection of the device allows it to be operated in different environments and, in consultation with the manufacturer, further modifications are possible to enable operation under user-specific environmental conditions. The output wiring from the transmitter cannot be routed next to power cables or other cables that may cause disturbance.

The equipment interoperating with the flowmeter has to be resistant to electromagnetic disturbance generated in the surroundings in accordance with the compatibility requirements applicable at the place of installation.

8.1. Grounding



The flowmeter has to be earthed according to the rules applicable at the place of installation.

Lack of functional earthing may cause significant disturbances of measurements.



Designation of the point of connection of the functional earthing on the flowmeter.



Protective grounding for high voltage version (230 V) as indicated in → [Table 5](#).

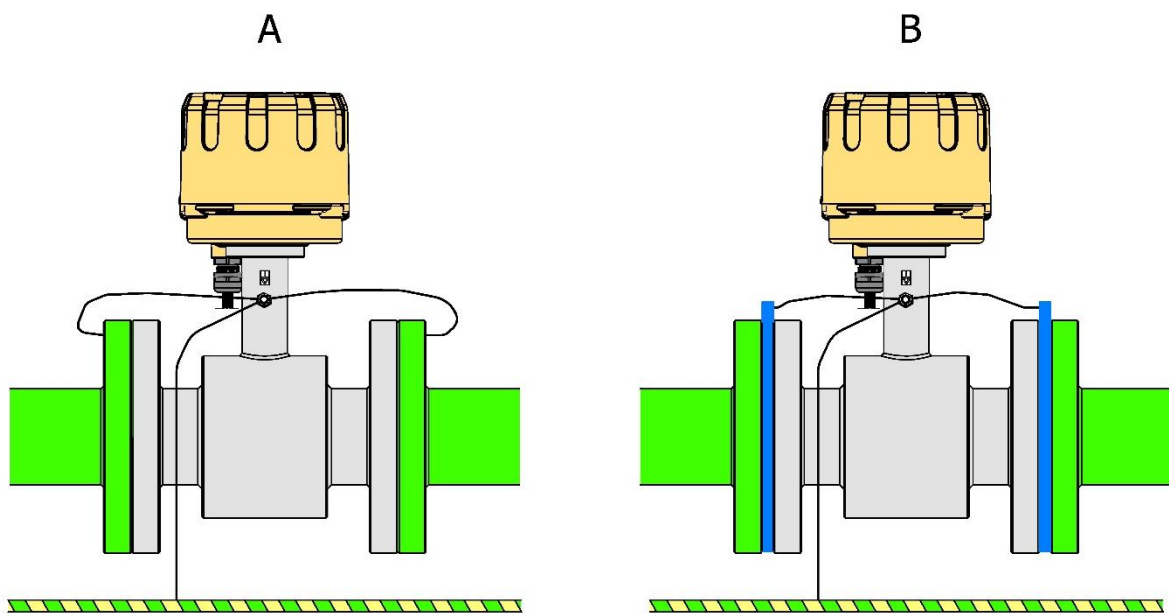
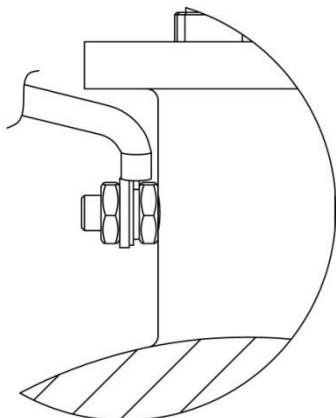

Figure 6. Example of functional earthing connection for metallic (A) piping and for insulated piping using earthing rings (B).



Connection elements according to the installation order:

1. Nut M6.
2. Conductor terminated with M6 terminal lug.
3. Toothed washer acc. DIN 6797 J – M6.
4. Spring washer M6.
5. Nut M6.

Figure 7. Connection of the functional earthing to the sensor enclosure.

9. START-UP

After the installation and electrical connection of the flowmeter, the installation and connections must be checked as follows:

- crimp all cable connections, terminals and plugs in all connectors and verify the earthing connection;
- verify the correct power supply according to the information on the equipment nameplate;
- verify the protection of the system against electric shock;
- check if the flowmeter is correctly installed in the piping (no clearances, gaps);
- if no defects and damage is detected in the system, fill the piping with liquid and verify its tightness. After short flushing, power cycle the system — on-off-on and start the measurement.



The description of the device configuration is given in the manual EN.IK.PEM.500, whereas the Modbus® communication is described in the manual EN.IM.PEM.500. The documentation is available on the manufacturer's website at www.aplisens.com.

10. TECHNICAL PARAMETERS

10.1. Electrical connections

10.1.1. Output signals

Analog output	Active or passive (special execution) 4 ... 20 mA/500 Ω
Pulse/frequency output	Passive Max. 24 V/10 mA DC, any polarity 0,1 ... 2000 Hz in frequency mode do 500 Hz in pulse mode galvanic isolated
2-state output OC	quantity: 1, open collector Max. 35 V DC/100 mA Galvanic isolated Any polarity
Communication output	Modbus RTU/RS485 Galvanic isolated

10.1.2. Power supply

Standard variant	Mains supply	90-260 V AC 50 Hz 15 VA
Optional variant	Low voltage supply	10-36 V DC 15 W Power input protected against reverse voltage polarity.

10.2. Protection class

The device has class I protection; it is equipped with protective terminal to which you should connect protective conductor. Measuring circuits (to sensor) are separated from hazardous voltages with reinforced insulation according to the requirements of PN-EN 61010-1.

10.3. Technical parameters

10.3.1. Technical specifications

Table 7. Technical data of PEM-500 flowmeter.

Technical data			
Minimum fluid conductivity	$\geq 5 \mu\text{S/cm}$	Nominal diameters	DN 10...250, (ANSI 0.5" ... 10")
Input resistance	$\geq 10^{10} \Omega$	Maximum pressure	Standard 1.6 MPa (2.5 MPa, 4 MPa)
Basic error*	$\pm 0.5\%$ of the reading value for 20...100% Qmax	Process connections	DIN flanges (ANSI, BS)
		Isolating lining	Hard rubber DN20...250 Teflon DN10...250
Small flows cut-off level	adjustable value	Fluid temperature for lining	Rubber: -5...90°C Teflon: -25...90°C
Momentary flow	2-way flow (l/s, m ³ /h, m ³ /s and others)	Electrodes	316L steel – rubber-lining design 316L, Hastelloy, Tantalum – Teflon-lining design
Volume balance	3 counters: total, positive, negative (m ³ , l and others)	Sensor pipe	acid resistant steel
Low flow alarm	Adjustable, any value	Outer enclosure and flanges	Carbon steel (steel 304, steel 321)
Configuration	RS485 and Modbus RTU protocol	Anti-corrosion protection	Acrymetal varnish
Empty pipe detection	Periodic, programmable	Accessories	Stainless steel earthing rings for plastic pipes
Analogue outputs	4...20 mA/500 Ω Active output (passive – special design)		
Pulse/frequency Output	max. 24 V / 10 mA DC; 0.1...2000 Hz in frequency mode; up to 500 Hz in pulse mode passive output, galvanic isolation; any polarity	Excitation coil insulation class	E
		Optional sensor design	acid resistant steel hygienic connections
Binary OC output	open manifold Max. 35 V DC / 100 mA galvanic isolation; any polarity	Weight	0.5 kg (transmitter weight) + Weight acc. to table 1, 2, 3 "Sensor mechanical data"
Communication output	Modbus RTU/ RS485 Galvanic isolation	Power cable (with mains power supply)	3 m
		Signal cable (with mains power supply)	3 m
Power supply	mains: 90...260 V AC / 50 Hz / 15 VA low voltage with protection against inverse voltage polarity: 10...36 V DC / 15 W	Power and signal cable (low voltage version)	3 m
		Other cable lengths – upon request	
Protection rating	IP67 (IP68)		

10.4. Reference conditions

Flow	0,3 – 10 m/s
Measured medium	Water 10 – 30°C
Conductivity	> 300 $\mu\text{S/cm}$
Supply variability	$U_n \pm 2\%$ (U_n – supply voltage)
Ambient temperature	18 - 25°C, constant humidity
Stabilization time after switching on the power supply	Minimum 20 min
Straight sections of flow	5 diameters upstream the sensor, 3 diameters downstream the sensor
Measuring sensor	Connected with transmitter, centrally located

NOTE! Reference conditions generally contain reference values or reference ranges for values affecting the flow meter.

10.5. Metrological parameters

10.5.1. Standard measuring ranges

PEM-500 flowmeters are available in the size ranges of flange connections specified by the DIN standard within the range DN10 ÷ DN250 or optionally can be executed in the size range of flange connections in accordance to the ANSI, BS standard.

Standard flow values Q_{max} for the individual versions of the flowmeters with flange connections in accordance with DIN in the range DN10 ÷ DN250 are presented in the table below. It is possible to set the other Q_{max} flow values for the individual versions of the flowmeters greater than twice the standard value of measuring range.

Table 8. Flow values for the PEM-500 flowmeter.

Flow values							
DN acc. to DIN	Recommended limit flow values		Factory settings				
	$\sim Q_{(min)}$	$\sim Q_{(max)}$	Analog output 4...20 mA		Pulse output		Low flow cut-off ($v \sim 0,1$ [m/s])
			Measuring range	Linear flow velocity (to the end of measuring range)	Volume / pulse	Number of pulses / m ³	
	[m ³ /h]	[m ³ /h]	[m ³ /h]	[m/s]	[m ³ /pulse]		[m ³ /h]
10	0,08	2,8	0÷1	3,54	0,000025	400000	0,03
15	0,19	6,4	0÷2	3,14	0,000005	200000	0,06
20	0,34	11	0÷4	3,54	0,00001	100000	0,12
25	0,5	18	0÷5	2,83	0,0000125	80000	0,15
32	0,9	29	0÷10	3,45	0,00004	40000	0,3
40	1,4	45	0÷15	3,32	0,00005	25000	0,45
50	2,1	71	0÷20	2,83	0,0001	20000	0,6
65	3,6	119	0÷30	2,51	0,000125	10000	0,9
80	5	181	0÷50	2,76	0,00025	8000	1,5
100	8	283	0÷100	3,54	0,0004	4000	3
125	13	442	0÷150	3,40	0,0005	2500	4,5
150	19	636	0÷200	3,14	0,001	2000	6
200	34	1131	0÷360	3,18	0,00125	1000	10,8
250	53	1767	0÷500	2,83	0,002	800	15

10.5.2. Table of volumetric flows calculated for characteristic fluid flow velocities for flanged execution acc. to DIN.

The volumetric flow is calculated from the measured linear velocity of the flow and the geometry of the flowmeter cross-section. The table shows the values of volume flow for individual DN's at characteristic linear flow speeds.

Table 9. Volume flow versus fluid linear velocity.

DN	Flow velocity V [m/s]							Flow [m ³ /h]
	0,300	1,000	2,000	3,000	4,000	5,000	6,000	
10	0,085	0,283	0,565	0,848	1,131	1,414	1,696	
15	0,191	0,636	1,272	1,909	2,545	3,181	3,817	
20	0,339	1,131	2,262	3,393	4,524	5,655	6,786	
25	0,530	1,767	3,534	5,301	7,069	8,836	10,603	
32	0,869	2,895	5,791	8,686	11,581	14,476	17,372	
40	1,357	4,524	9,048	13,572	18,096	22,619	27,143	
50	2,121	7,069	14,137	21,206	28,274	35,343	42,411	
65	3,584	11,946	23,892	35,838	47,784	59,729	71,675	
80	5,429	18,096	36,191	54,287	72,382	90,478	108,573	
100	8,482	28,274	56,549	84,823	113,097	141,372	169,646	
125	13,254	44,179	88,357	132,536	176,714	220,893	265,072	
150	19,085	63,617	127,234	190,852	254,469	318,086	381,703	
200	33,929	113,097	226,194	339,292	452,389	565,486	678,583	
250	53,014	176,714	353,429	530,143	706,858	883,572	1060,287	

Table 10. Flow values corresponding to the velocity of 1 m/s.

Flow values corresponding to the velocity 1 m/s			
DN	m ³ /h	l/min.	l/s
10	0,283	4,712	0,079
15	0,637	10,62	0,177
20	1,131	18,85	0,314
25	1,767	29,452	0,491
32	2,895	48,255	0,804
40	4,524	75,398	1,257
50	7,069	117,81	1,964
65	11,946	199,1	3,318
80	18,096	301,59	5,027
100	28,274	471,23	7,854
125	44,179	736,31	12,272
150	63,617	1060,3	17,671
200	113,10	1885	31,42
250	176,71	2945,2	49,087

10.5.3. Available pressure ranges acc. to DIN, ANSI of flowmeters operation for individual designs of DN size of flange connections

DIN PN16	DIN PN25	DIN PN40	ANSI150lb	ANSI 300lb
DN10	DN10	DN10	DN10	DN10
DN15	DN15	DN15	DN15	DN15
DN20	DN20	DN20	DN20	DN20
DN25	DN25	DN25	DN25	DN25
DN32	DN32	DN32	DN32	DN32
DN40	DN40	DN40	DN40	DN40
DN50	DN50	DN50	DN50	DN50
DN65	DN65	DN65	DN65	DN65
DN80	DN80	DN80	DN80	DN80
DN100	DN100	DN100	DN100	DN100
DN125	DN125	DN125	DN125	DN125
DN150	DN150	DN150	DN150	DN150
DN200	DN200	DN200	DN200	DN200
DN250	DN250	DN250	DN250	DN250

10.5.4. Selection of the diameter and measuring range of the flowmeter

Selection of the appropriate flowmeter diameter depends on the diameter of the piping on which it will be installed, as well as on the flow rate of the liquid carried in that piping. The minimum measuring range of a given flowmeter corresponds to a linear liquid flow velocity of 0.3 m/s, while the maximum measuring range is for the liquid flow at 10 m/s. The optimum measuring ranges correspond to linear fluid flow velocity between 2 and 3.5 m/s.

The factory settings of measuring ranges taking into account the optimum linear flow velocities are specified in → **Table 8**. Measurement with linear liquid velocity lower than 0.1 m/s is not recommended.

Factory calibration of flow meters is performed at a flow velocity of approx. 6 m/s, and the result is specified on the calibration certificate, which is supplied together with the flowmeter.

The flow velocity should also take into account the physical properties of the fluid. For erosive liquids such as water with sand or gravel, lime slurry, velocities below 2 m/s are recommended. Fouling liquids, e.g. waste sludge, should travel at a speed higher than 2 m/s during measurement.

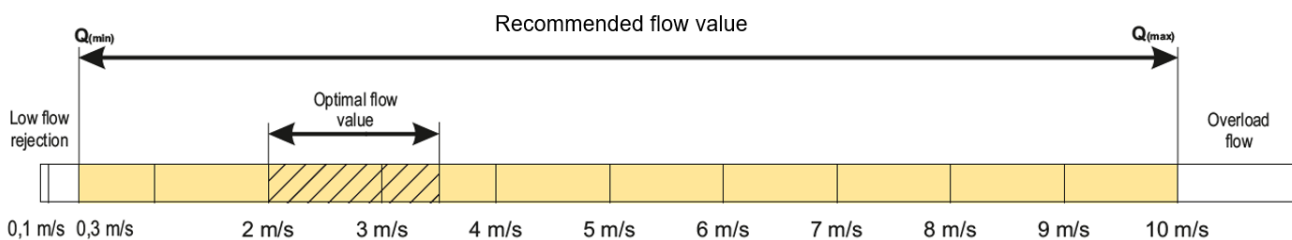

Figure 8. Recommended flow values for the PEM-500 flowmeter.

Mapping of the momentary flow value with a 4...20 mA current signal is limited to the flow range determined by the parameters in accordance with Fig. 7.

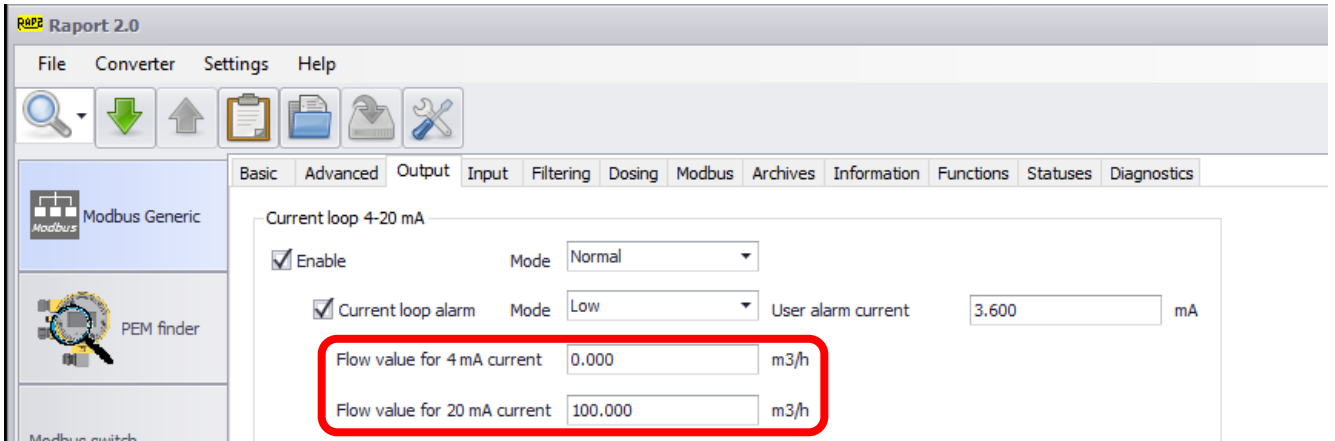

Figure 9. “Outputs” tab view – setting the flow values for 4 mA and 20 mA current.

“4 mA flow value” and “20 mA flow value” (with the unit identical to the one set in the “Flow unit” option in the “Basic” tab).



The manufacturer guarantees maintenance of the declared accuracy class between 10% and 100% Qmax.

10.6. Permissible ambient and operating parameters

Ambient temperature	-20 ... 60°C
Relative humidity	to 80%
Surrounding atmosphere	No aggressive ingredients
Height above sea level	to 2000 m



The permissible ambient and operating parameters of the device must not be exceeded. Exceeding them may result in increased measurement errors.

11. MAINTENANCE

11.1. Periodic inspections

Periodic inspections must be carried out in accordance with applicable standards. During the inspection, check the condition of the electrical connections and the stability of the flowmeter mounting.

11.2. Non-periodic inspections

If it is likely that the device at the installation location has been exposed to mechanical damage, overvoltage or improper operation has been identified, the device should be inspected. If there is no signal in the measurement line or its value is incorrect, check the condition of the cable, the connections, etc. Check whether supply voltage and load resistance are correct. If the power line works properly, check the functioning of the flowmeter.

11.3. Cleaning / washing

- Cleanliness of electrodes can affect the precision of the measurement and the accumulation of dirt can affect the measuring process (liquid isolation).
- Upon delivery, the electrodes do not need to be cleaned before installation in the piping. It is recommended to use a clean cloth or a cloth and detergent for cleaning the electrodes. Damage to the lining must be avoided. If the electrodes must be cleaned during operation, also mechanical and electrolytic methods may be used. Mechanical cleaning can only be carried out with a suitable equipment that is appropriate for the sensor, otherwise the flowmeter must be removed from the piping. After cleaning, reinstall the flowmeter.
- The electrolytic method is favourable due to its simplicity, but it can only be used for impurities that can be removed by electrolysis (small impurities and sediments).
- If the flowmeter operates under normal conditions, for most liquids it does not require cleaning throughout its service life, self-cleaning by the flowing liquid is sufficient. This process is particularly effective at flow velocity of approx. 3 m/s.



In the case of systems intended for the measurement of viscous or highly contaminated substances, it is recommended to install two Y fittings with stoppers (upstream and downstream of the flow meter), which will enable cleaning of the device without removing it.

12. SCRAPPING, DISPOSAL



Worn or damaged devices shall be scrapped in accordance with WEEE Directive (2012/19/EU) on waste electrical and electronic equipment or returned to the manufacturer.

13. ADDITIONAL INFORMATION

The manufacturer reserves the right to introduce design and process changes in the device not decreasing its performance parameters.

13.1. History of revisions

Revision No.	Document revision	Description of changes
-	01.A.001/2020.08	First version of the document. Prepared by DBFD.

